

1) TOOL TYPE - GERAETETYP - DESCRIZIONE MACCHINA - TYPE D'OUTIL - TIPO DE MAQUINA
 cod. 11313 FM 35-15/18

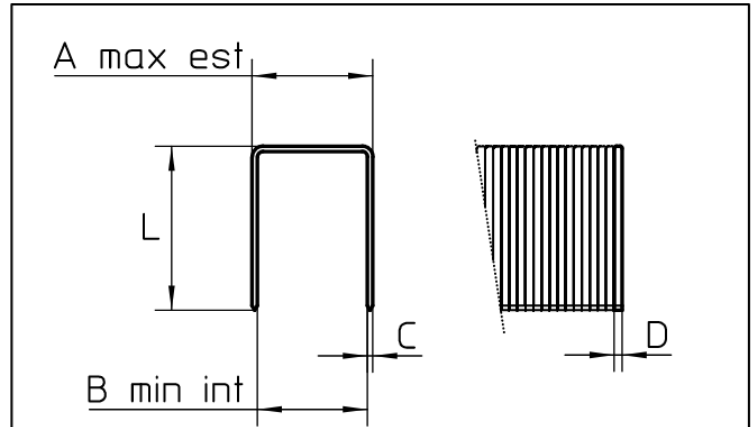
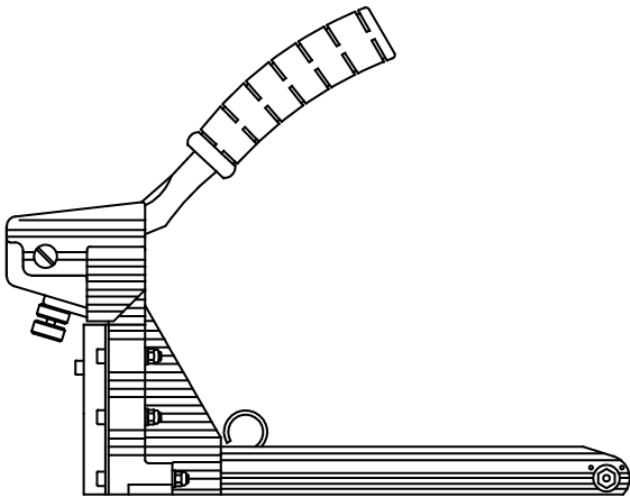

2) TOOL CHARACTERISTICS
 SPEZIFIKATION DES GERAETES
 CARATTERISTICHE TECNICHE
 CARACTÉRISTIQUES DE L'OUTIL
 CARACTERÍSTICAS DE LA MAQUINA

HEIGHT HOEHE ALTEZZA HAUTEUR ALTURA	WIDTH BREITE LARGHEZZA LARGEUR ANCHURA	LENGTH LAENGE LUNGHEZZA LONGUEUR LONGITUD	WEIGHT GEWICHT PESO POIDS PESO
in. 11.61 mm. 295	in. 4.72 mm. 120	in. 14.80 mm. 376	lbs. 3.88 kg. 1.760
MIN-MAX WORKING PRESSURE MIN-MAX ARBEITSDRUCK MIN-MAX PRESSIONE DI ESERCIZIO MIN-MAX PRESSION DE TRAVAIL MIN-MAX PRESSION DE TRABAJO			
AIR CONSUMPTION PER SHOT LUFTVERBRAUCH PRO NAGELUNG CONSUMO ARIA PER COLPO CONSUMATION DE L'AIRE PAR COUP CONSUMO DE AIRE CADA DISPARO			
LUBRICANT SCHMIEROEL LUBRIFICANTE LUBRIFIANT LUBRIFICANTE		AEROSPACE LUBRICANTS TRIBOLUBE 12	

3) FASTENER DATA
 ANGABEN ZU DEN BEFESTIGUNGSMITTELN
 CARATTERISTICHE TECNICHE FISSAGGI
 DONNÉES DES PROJECTILES
 DATOS DE CLAVOS

A) OUTSIDE CROWN AUSSEN RUECKEN LARGHEZZA EST. CORONNE EXT. CORONA EXT.	MAX	in. 1.366 mm. 34.70
B) INSIDE CROWN INNEN RUECKEN LARGHEZZA INT. CORONNE INT. CORONA INT.	MIN	in. 1.295 mm. 32.90
CxD) WIRE DRAHT FILO FIL ALAMBRE		in. 0.035 x 0.090 mm. 0.90 x 2.30
L) LENGTH LAENGE LUNGHEZZA LONGUEUR LONGITUD	MIN-MAX	in. 5/8" - 3/4" mm. 15 - 18
MAGAZINE CAPACITY MAGAZIN CAPAZITAET CAPACITA' CARICATORE CAPACITE' CHARGEUR CAPACIDAD CARGADOR		100 staples

* ACTUATION SYSTEM * AUSLOESEART * ATTUAZIONE * MISE EN OEUVRE * ACTUACIÓN	5 (SAFETY : NO)
--	-----------------

* LOADING	BOTTOM LOADING
* LADEN	SIDE LOADING
* CARICAMENTO	● TOP LOADING
* CHARGER	COIL
* CARGA	OTHER

* SEE INSTRUCTION MANUAL - SIEHE BETRIEBSANLEITUNG - VEDI MANUALE - VOIR MODE D'EMPLOI - VER EL MANUAL

NOISE CHARACTERISTICS GERÄUSCH - EMISSION DATEN CARATTERISTICHE RUMOROSITA' CARACTÉRISTIQUES ACOUSTIQUE CARACTERÍSTICAS DE RUIDO	
--	--

VIBRATION VALUE VIBRATIONSWERT VALORE DI VIBRAZIONE VALEUR DE VIBRATION VALOR DE VIBRACIÓN	
--	--