

SK20 Semi-Automatic Carton Sealers



RELIABLE MACHINE
Strong frame with
dual masts structure



TIME SAVING SOLUTION
Fast removable
top taping head

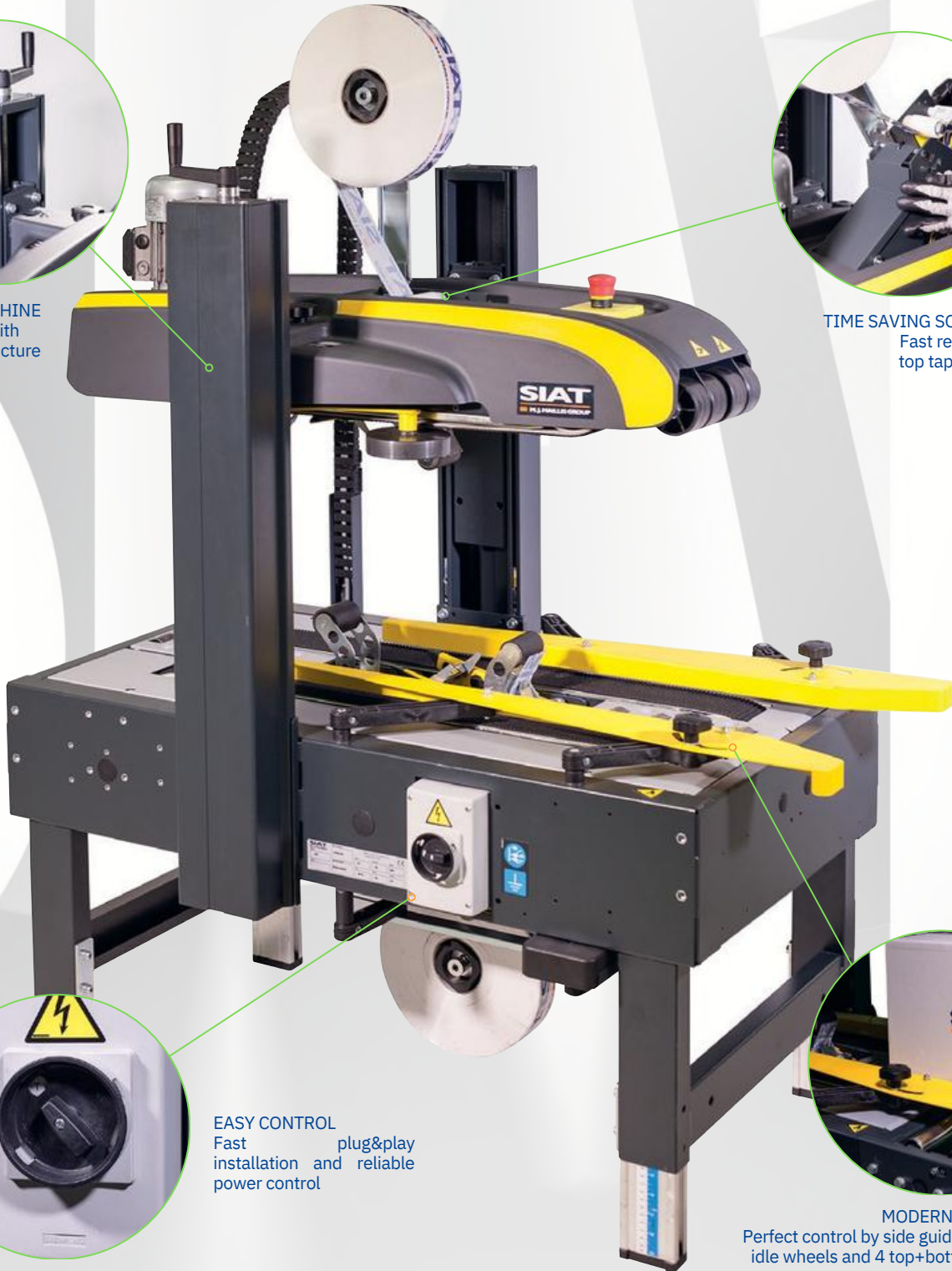

EASY CONTROL
Fast plug&play
installation and reliable
power control



MODERN DESIGN
Perfect control by side guides, upper
idle wheels and 4 top+bottom belts



The new case sealer SK20 represents the perfect solution for your semi-automatic packaging line.

The concept, with the double top and bottom drive belts, allows the control of the carton box also during the incoming process before sealing.

Thanks to the robust dual masts frame and to the primary level of the machine components, the historical reliability of SIAT machines is fully guaranteed.

The easy plug&play mode and the fast-removable taping head help the customer to save time efficiently during set-up and maintenance operations.

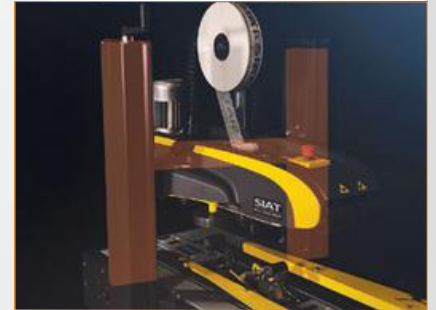
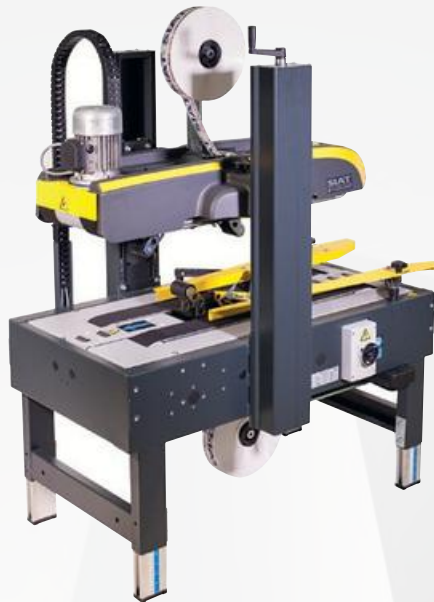

other languages: www.casacoding.com



> Machine dimensions
Dimensioni macchina
Machinemessungen
Dimensions de la machine
Dimensiones de máquina

Packaging size / weight			LxWxH
>SK20 150	170		114x78x115

> SK20

Min.	Max		
		L 1080 -	
		W 740 -	
H 1290	1630	cbh 485	825
		AS 77cbh +110cbh +110 AS	
		80cbh +160cbh +160	

> SK20

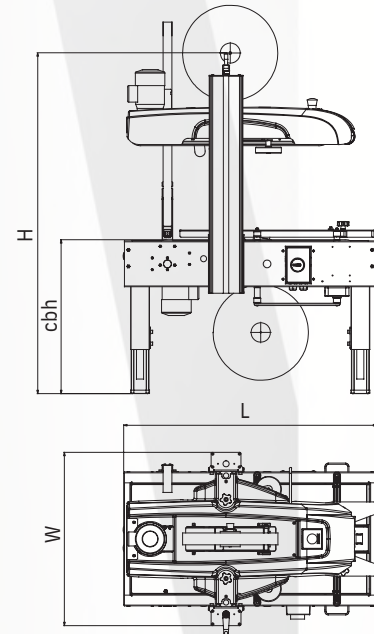

> Box dimensions
Dimensioni delle scatole
Kartonabmessungen
Dimensions des boîtes
Dimensiones de cajas

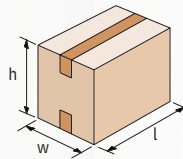

> SK20

K11R std. / K12R on demand	
Min.	Max
h 150	∞
w 140	170/500
l 100	500

* With top side pressure rollers (minimum width manageable 205 mm).
Upper guides required in case of box width less than 205 mm (optional).

> Production capacity
Capacità di produzione
Produktionskapazität
Capacité de production
Capacidad de producción

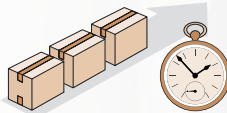

>SK20	Bph
Max pcs.*	1200

* Always based on shorter manageable box

> Standard voltage
Voltaggio standard
Standardspannung
Tension standard
Voltaje estándar

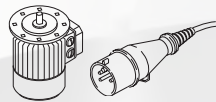

> SK20

380/415V - 50Hz - 3P
Amps 1,08
Power kW0,26
Phase 3Ph + N + PE

> Taping units

Unità nastranti
K11R/Verschliesseinheiten
mm Unités enrubanneuses
A410 Max Unidades de precinto



> Optionals
Accessori
Zubehör
Accessories
Accesorios

> AS80
Higher legs
Set gambe più alte
Höhere Stützen
Pieds plus hauts
Patas más altas

> AS77
Casters
Set ruote
Rädchen
Roulettes
Ruedas

> RG
Roller conveyor
Piani a rulli
Rollenbahnen
Plans à rouleaux
Rodillos libres

> GTL - GTR - K-125 / K-250

Extendable conveyor
Rulliera estensibile
Ausziehbare rollenbahnen
Convoyeur extensible
Inkjet printer
Stampante ad inchiostro
Tintenstrahl drucker
Marqueur à jet d'encre
Rodillos extensibles
Impresora de inyección de tinta

